



# DID YOU KNOW SALES TIPS

## From DSC® ...How to Replace DVACS

In a traditional DVACS installation, a DVACS panel is connected to a F1/F2 subset and a DVACS communication circuit which then facilitates communication to a central monitoring station equipped with a DVACS Central Station Receiver.

DSC's TL250D can be used in place of the existing DVACS F1/F2 subset (*Figure 1*). Simply connect the TL250D to an existing Sur-Gard DVACS panel or DSC DVACS communicator. The TL250D will then take the DVACS output from the Sur-Gard panel or DSC communicator and communicate the event over the client's internet connection.

This simple and cost effective upgrade maintains the existing DVACS panel, maintains or increases the ULC monitoring level (*ULC Level 3, 4 or 5*), but will eliminate the clients' monthly DVACS cost.

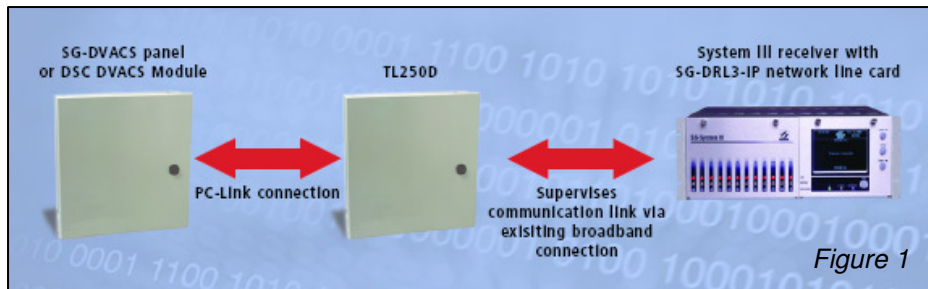

Figure 1

Another option for ULC fire monitoring applications is to use DSC's ULC listed "GS3060" GSM Communicator and "KIT16-512C" ULC Fire Kit.

The "KIT16-512C" kit comes with a PC1616 – 6 zone (*expandable to 16 zones*) hybrid control panel with dual battery leads, a PC4050CR red fire cabinet with pre-mounted transformer, a PK5501 fixed icon keypad, a tamper bracket and switch, and a ULC sticker mounted on the cabinet.

In this option, the GS3060 connects the PC1616ULC panel (*Figure 2*) to the GSM network and reports fire alarm signals directly to a monitoring station using the PSTN and GSM network. This option is fully approved by ULC.

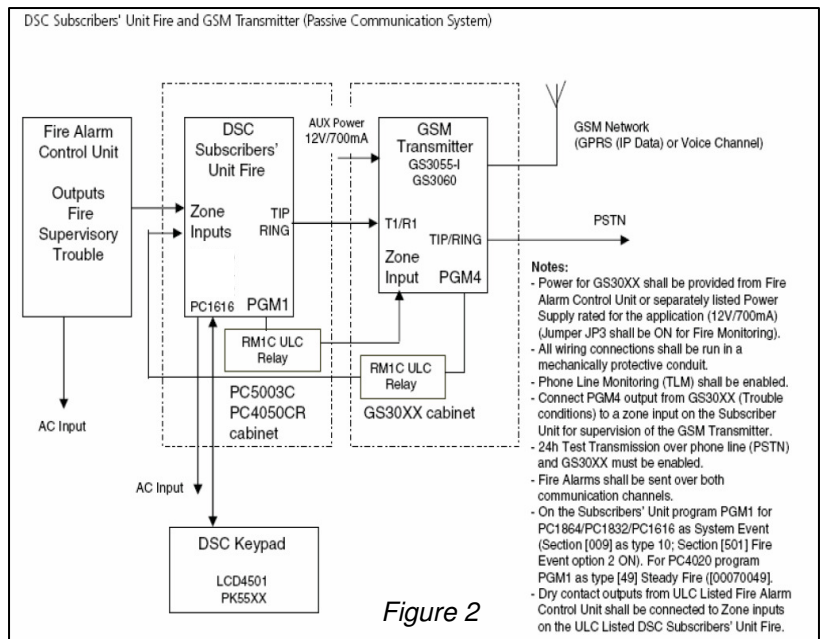

Figure 2